

M7410E

SMALL MODULATING LINEAR VALVE ACTUATOR

PRODUCT DATA

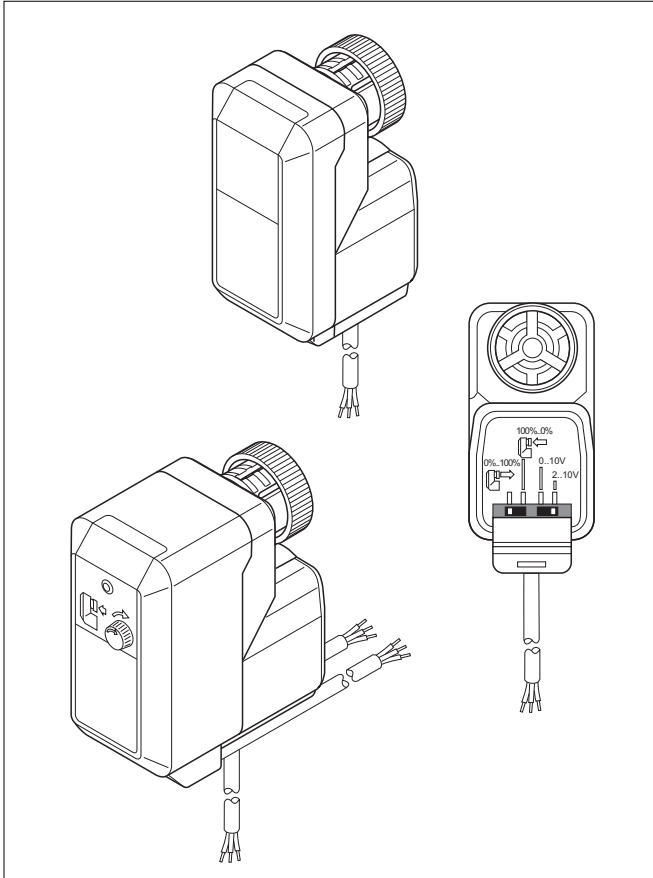

APPLICATION

The Honeywell M7410E1xxx, M7410E2xxx, and M7410E4xxx actuators are specifically designed to provide modulating control together with the V5822/23, V5832/33, and V5825B series of small linear valves. The M7410E5001 is designed for use with the V5003TY1xxx and V5003TY2xxx Kombi-QM valves.

The M7410E is used in fan-coil-units, induction units, small reheaters and recoolers, and for zone control applications. It is employed in electronic temperature control systems with hot and/or cold water as the controlled medium. This actuator is fully compatible with all controllers providing 0...10 V or 2...10 V output signals.

The M7410E actuator is designed for applications where space is limited and minimum power consumption is required. A microprocessor-based, high-performance positioner guarantees accurate control.

Reliable long-term operation is ensured due to the fact that no mechanical feedback potentiometer and no mechanical end-switches are needed. Due to an automatic synchronization function, the close-off point is self-adjusting.

Based on a running time of 150 sec (M7410E5001: 95 sec), valve positioning and flow adjustment is very exact. Manual positioning is provided for all actuators. The actuator is both attractive and robust in design. A special version with auxiliary switch is available.

FEATURES

- Microprocessor-based positioner ensures precise stem positioning
- Small size allows installation where space is limited
- Low power consumption
- Suitable for 0...10 V and 2...10 V controller output signal (adjustable on site)
- Easy-to-operate direct/reverse acting switch
- Simple input signal override (e.g., for frost protection function)
- Reliable long-term operation because mechanical feedback potentiometers and mechanical end switches are not required
- Magnetic coupling for stem force limitation and self-adjustment of the close-off point
- Supplied with pre-wired connection cable
- Simple, standardized valve/actuator coupling. No tools required for mounting
- Visual valve position indicator furnished with actuator (the M7410E5001 does not feature a position indicator)
- Manual operation provided by the valve adjustment cap, extra knob, or with a hexagon key

SPECIFICATIONS

Motor

Input voltage:	24 Vac \pm 15%; 50/60 Hz
Power consumption:	1.8 VA / 1.2 W (motor running) 0.6 VA / 0.2 W (motor stopped)
Input signal:	modulating 0...10 V, 2...10 V (adjustable); < 0.1 mA
Operation:	direct/reverse (adjustable)
Stroke:	18 mm - 11.5 mm = 6.5 mm (M7410E5001: 14.3 mm - 10.3 mm = 4 mm)
Running time:	150 s (M7410E5001: 95 s) at 50 Hz 125 s (M7410E5001: 80 s) at 60 Hz
Stem force:	depending on type (see table) 180 N (for valves DN 15..20) 300 N (for valves DN 25..40 & V5825B) 90 N (M7401E5001)
Protection standard:	IP 42 in accordance with EN 60529
Insulation class:	III in accordance with EN 60730
Connection cable:	1.5 m
Ambient operating temperature limits:	0...55 °C
Medium valve temperature:	max. 120 °C
Weight:	0.4 kg

Suitable valves: see section "Versions" below

Manual operation: see section "Versions" below

Auxiliary Switches

Ratings:	5...24 V max. 100 mA 24...230 Vac, max. 3(1) A	
Switch position (factory supplied):	Switch S1 (fix)	17.8 \pm 0.2 mm
	Switch S2 (adjust.)	11.7 \pm 0.2 mm

OPERATION

The movement of the electric actuator is produced by a screw spindle which is driven in both directions by a synchronous motor through a set of gears. A magnetic clutch limits the torque of the gear assembly and the driving force of the actuator. The actuator is fixed to the valve body by means of a coupling ring requiring no tools for mounting. The actuator is maintenance-free and supplied completely with a ready-to-wire connecting cable.

A microprocessor-based high performance positioner guarantees accurate control. The close-off position is self-adjusting by means of an automatic synchronization function. Synchronization is performed when the applied control signal is 0 V or 10 V. The actuator then drives every minute for 5 seconds into the end position in order to ensure close-off even after manual operation.

VERSIONS

	manual operation	stem force	aux. switch S1	aux. switch S2	housing type	OS number
Standard	Provided by the valve adjustment cap	180 N 300 N 90 N	– – –	– – –	B B B	M7410E1002 M7410E1028 M7410E5001
With manual operation	Integrated	180 N 300 N	– –	– –	C C	M7410E2026 M7410E2034
With manual operation and auxiliary switches	Integrated	180 N 300 N	x x	x x	C C	M7410E4022 M7410E4030
Special versions	Special cable lengths: 3 m / 5 m / 10 m					upon request

MOUNTING POSITION

The actuator may be mounted only beside or above the valve. Adjust the valve in the correct position before mounting the actuator.

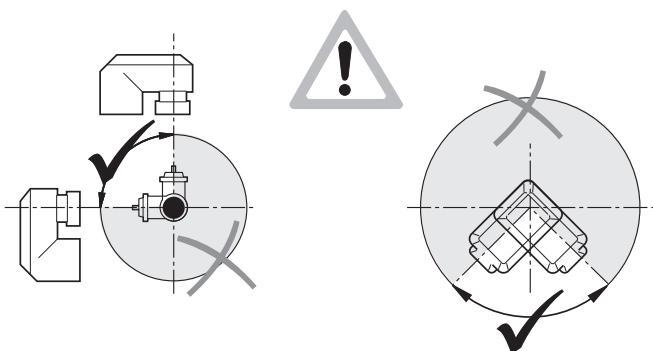

Fig. 1. Mounting positions

MOUNTING

Before the actuator is fixed to the valve, the adjustment cap must be removed (Fig. 2). Make sure that the actuator is in the open position (factory-supplied position) before fixing the actuator to the valve body.

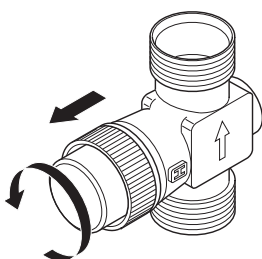

Fig. 2. Removing protection cap

The actuator must be mounted by hand. Do not use tools or additional force insofar as this may damage the actuator and valve.

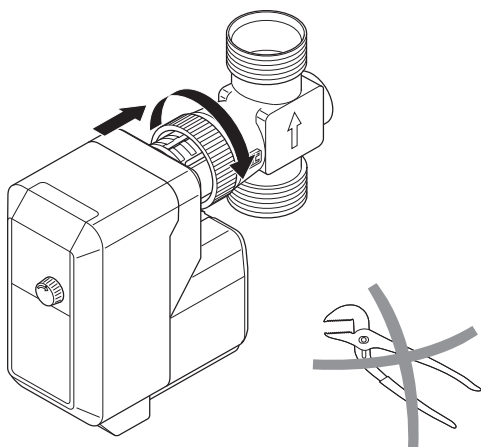

Fig. 3. Mounting the actuator

SWITCH SELECTION

The built-in selector switches must be set according to the valve type (2-way or 3-way), valve size, and the controller output signal (0...10 V or 2...10 V), see Fig. 4.

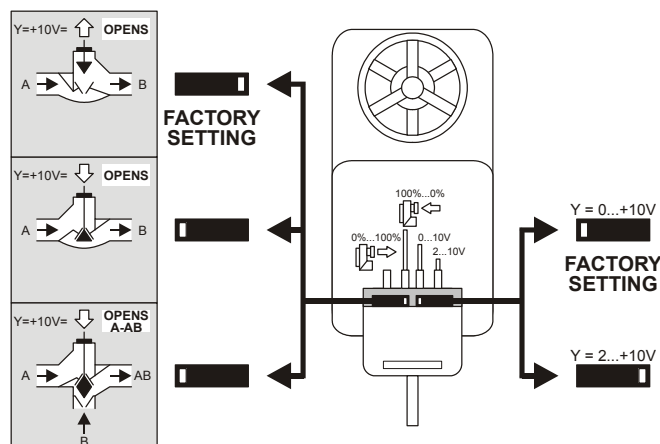

Fig. 4. Selecting valve type and output signal

ELECTRIC WIRING

The electrical installation must comply with Fig. 5.

INPUT SIGNAL OVERRIDE

To override the controller output signal, the input signal must be connected to COM (0 %) or 24 V (100 %) using an external switch (see Fig. 5).

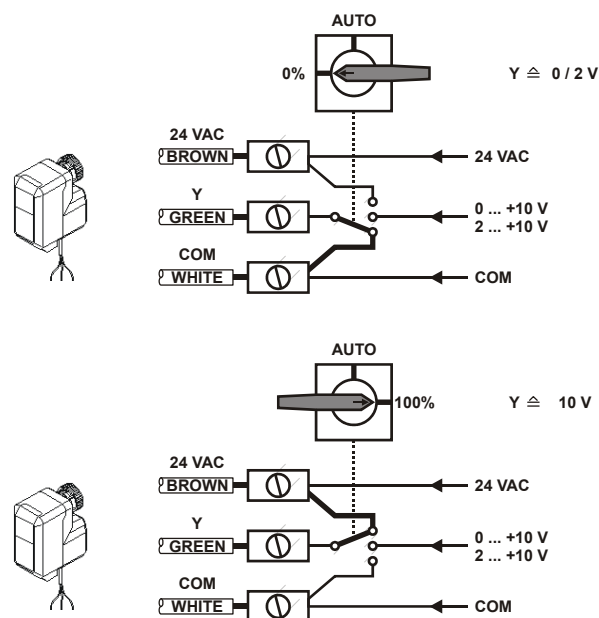

Fig. 5. Connection of input switch

MANUAL OPERATION

Actuators with the OS-number M7410E2... and M7410E4... feature a hexagonal key hole for manual operation. For more comfort, an additional knob for manual adjustment is supplied (packed separately). To prevent valve damage, operation is permitted only when there is no power applied to the motor.

Alternatively, the hexagonal key hole can be sealed by inserting the small white plastic plug (packed separately).

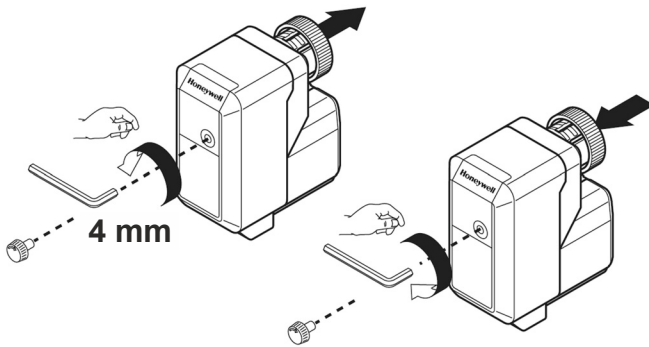

Fig. 6. Manual operation

COMMISSIONING ADVICE

A functional check of the valve actuator can be carried out by changing the Y input signal. The red position indicator (not featured by the M7410E5001) indicates the movement of the actuator stem and whether the valve is opening or closing (see Fig. 7) If the direction of travel is not correct, the direct / reverse-switch must be reset.

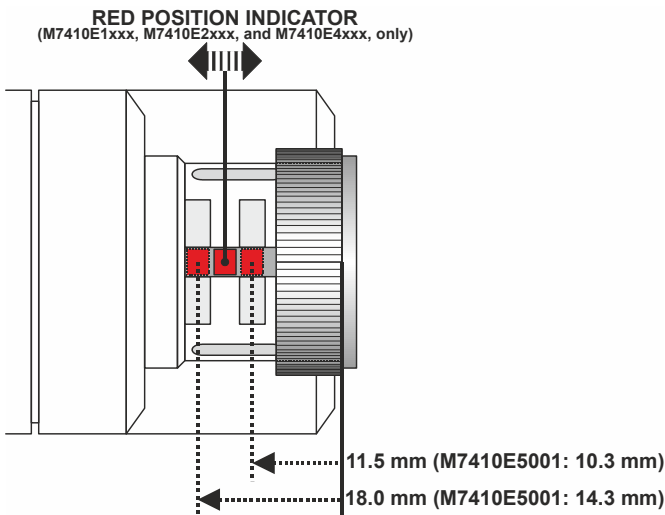

Fig. 7. Movement of the actuator stem (view from above)

AUXILIARY SWITCHES

The M7410E4022 and M7410E4033 feature two auxiliary switches, each with its own cable:

- Auxiliary switch S1 has a fixed switchpoint when the stem position is in.
- Auxiliary switch S2 has an adjustable switchpoint when the stem position is out.

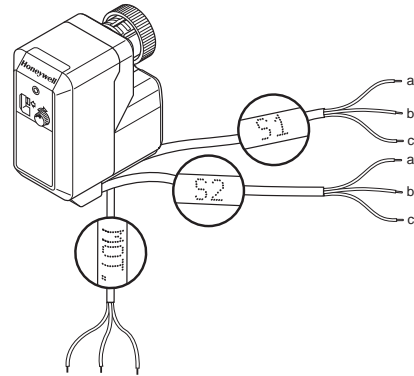

Fig. 8. Auxiliary switch cables

Adjustment of Auxiliary Switch 2

NOTE: The auxiliary switch should be adjusted by a skilled person, only.

Move the actuator to the position where the switch is to be operated. Cut the plastic skin with a sharp knife. The adjustment screw can be accessed below the skin. Turn the screw clockwise until the end stop is reached. Turn the screw counterclockwise until the switch point is achieved. To check that the required position has been set, move the actuator. Finally, seal the adjustment hole by inserting the small white plastic plug (packed separately).

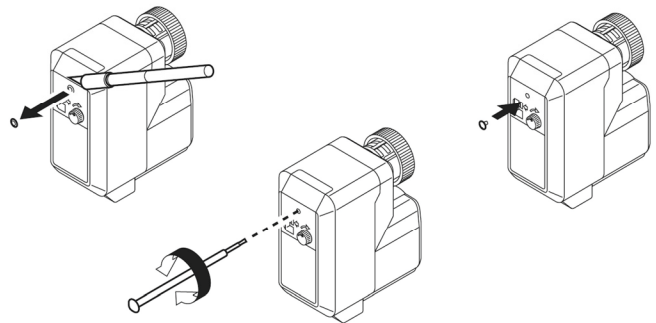
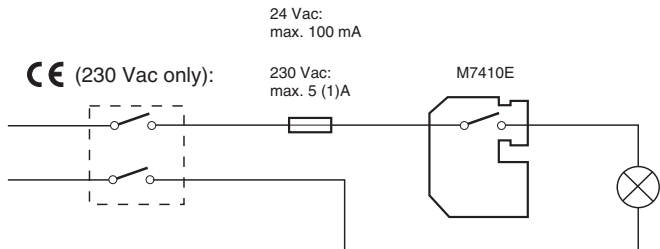

Fig. 9. Adjustment of auxiliary switch S2

Electric Wiring of Auxiliary Switches

The electrical installation must comply with the wiring diagram shown in Fig. 10 (the M7410E5001 does not feature a position indicator). If the auxiliary switch is connected to 230 Vac, a switch with a contact gap of at least 3 mm for each pole must be fitted with the installation.



DN 15, DN 20	open 		close
DN 25 - DN 40	close 		open
DN 15 - DN 40	close 		open
DN 15 - DN 20	close 		open
S1	BROWN BLUE BLACK	BROWN BLUE BLACK	BROWN BLUE BLACK
S2	BROWN BLUE BLACK	BROWN BLUE BLACK	BROWN BLUE BLACK

Fig. 10. Electric wiring of auxiliary switch

Application Example: Switching Off an Electrical Appliance 2-Way-Valve

DN 15, DN 20

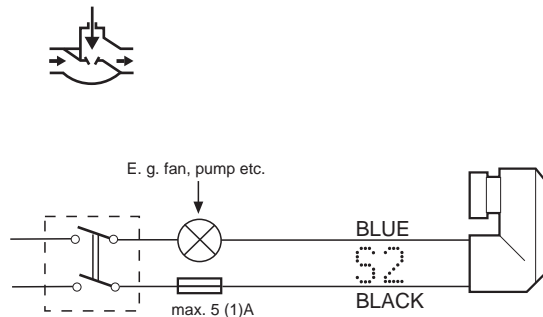

Fig. 11. Electric wiring of auxiliary switch

All Other Valves

DN 15 - DN 40 DN 15 - DN 20 DN 25 - DN 40

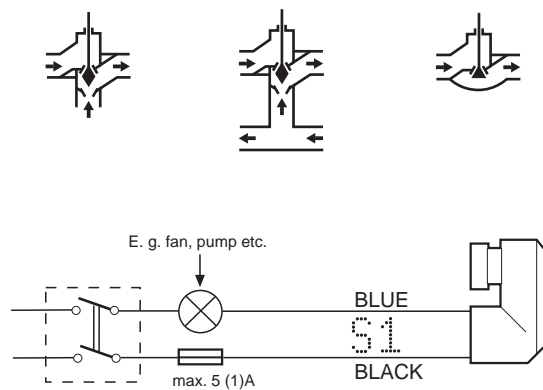

Fig. 12. Electric wiring of auxiliary switch

DIMENSIONS (MM)

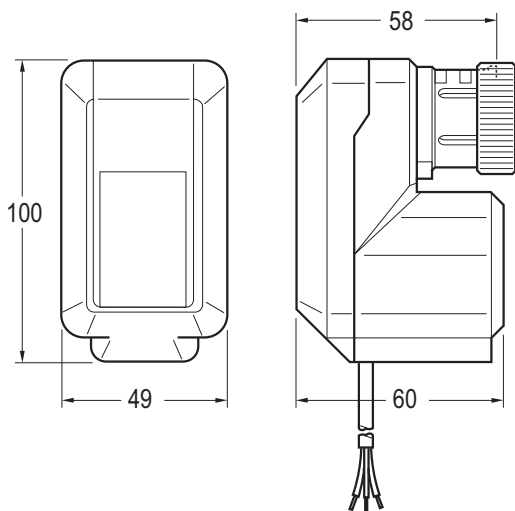

Fig. 13. Housing type B

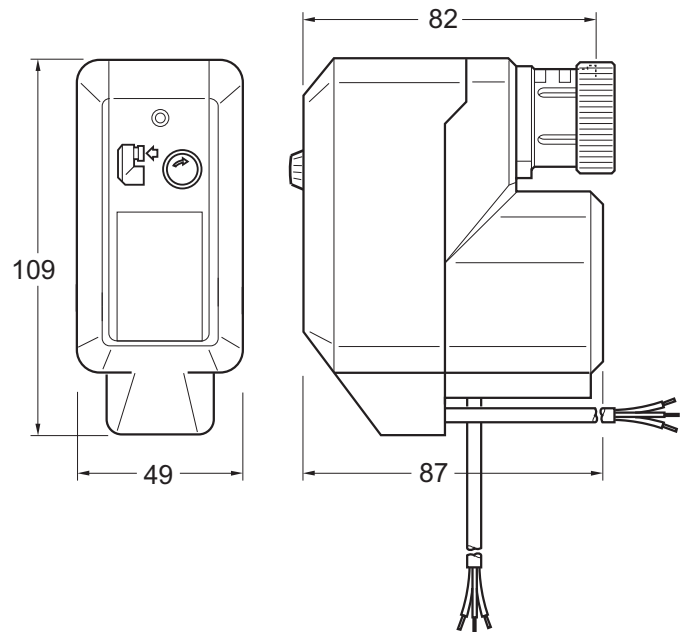

Fig. 14. Housing type C

Honeywell

Manufactured for and on behalf of the Environmental and Combustion Controls Division of Honeywell Technologies Sàrl, Rolle, Z.A. La Pièce 16, Switzerland by its Authorized Representative:

Automation and Control Solutions

Honeywell GmbH

Böblinger Strasse 17

71101 Schönaich / Germany

Phone: (49) 7031 63701

Fax: (49) 7031 637493

<http://ecc.emea.honeywell.com>

Subject to change without notice. Printed in Germany

EN0B-0097GE51 R0513